

FICHE D'HOMOLOGATION / HOMOLOGATION FORM



040-EM-12



COMMISSION
INTERNATIONALE
DE KARTING - FIA



MOTEUR / ENGINE MINI

Constructeur / <i>Manufacturer</i>	IAME SPA - SU
Marque / <i>Make</i>	IAME
Modèle / <i>Model</i>	GR-3
Catégorie / <i>Categorie</i>	Group 3
Durée de l'homologation / <i>Validity of the Homologation</i>	2 ans / 2 years
Nombre de pages / <i>Number of pages</i>	14
La présente Fiche d'Homologation reproduit descriptions, illustrations et dimensions du moteur au moment de l'homologation CIK-FIA.	<i>This Homologation Form reproduces descriptions, illustrations and dimensions of the engine at the moment of the CIK-FIA homologation.</i>
	
Photo du moteur complet côté pignon / <i>Photo of the complete engine drive side</i>	Photo du moteur complet côté opposé / <i>Photo of the complete engine opposite side</i>
Signature et tampon de l'ASN / <i>Signature and stamp of the ASN</i>	Signature et tampon de la CIK-FIA / <i>Signature and stamp of the CIK-FIA</i>
	

INFORMATIONS TECHNIQUES / TECHNICAL INFORMATION

A Caractéristiques / Characteristics

Le nombre de décimales doit être de 2 ou en accord avec la tolérance appliquée. /
The number of decimal places must be 2 or comply with the relevant tolerance.

Tolérances et remarques /
Tolerances & remarks

Cylindre / Cylinder		
Volume du cylindre / <i>Cylinder volume</i>	59.00 cm ³	< 60 cm ³
Alésage d'origine / <i>Original bore</i>	41.80 mm	--
Alésage théorique maximum / <i>Maximum theoretical bore</i>	< 42.10 mm	
Course / <i>Stroke</i>	43.0 mm	±0.1 mm
Vilebrequin / Crankshaft		
Nombre de lumières d'admission / <i>Number of intake ports</i>	1	--
Largeur des lumières d'admission* / <i>Width of intake ports*</i>	26.0 mm	+0.1/-0.2 mm
Nombre de conduits/lumières de transfert, cylindre/carter / <i>Number of transfer ports/ducts, cylinder/sump</i>	2	--
Largeur des lumières de transfert* / <i>Width of transfer ports*</i>	24.6 mm	+0.4/-0.2 mm
Nombre de lumières d'échappement / <i>Number of exhaust ports</i>	1	--
Largeur des lumières d'échappement* / <i>Width of exhaust ports*</i>	28.0 mm	+0.1/-0.2 mm
Forme de la chambre de combustion / <i>Shape of combustion chamber</i>	Gabarit / <i>Template CIK</i>	
Bielle / Conrod		
Poids du vilebrequin complet, sans piston / <i>Weight of crankshaft complete, without piston</i>	1215 gr	±3 % total
Dimensions des paliers / <i>Dimensions of bearings</i>	20 x 47 x 14	en/in mm
Type des paliers / <i>Type of bearings</i>	Roulement à rouleaux / <i>Roller bearing</i>	
Piston / Piston		
Nombre de segments du piston / <i>Number of piston rings</i>	1	--
Poids du piston, segments du piston inclus / <i>Weight of the piston including piston rings</i>	63.0 gr	±10 % total
Taille de l'axe de piston / <i>Size of gudgeon pin</i>	35 x 12 mm	±0.8 mm
Poids de l'axe de piston / <i>Weight of gudgeon pin</i>	12.0 gr	±10 % total

* Toutes les dimensions peuvent être vérifiées à l'aide du gabarit du constructeur / All dimensions can be checked using the manufacturer's template

B	Angles d'ouverture / Opening angles		
	Lumière d'admission / Intake port	144.0°	+0 / -2°
	Lumière de transfert / Transfer port	114.0°	+0 / -2°
	Lumière d'échappement / Exhaust port	156.0°	+0 / -2°

C	Matériau / Material	
	Culasse / Cylinder head	AL-SI
	Cylindre / Cylinder	AL-SI / FONTE
	Carter / Sump	AL-SI
	Vilebrequin / Crankshaft	ACIER NI-CR-MO
	Bielle / Connecting rod	ACIER NI-CR-MO
	Piston / Piston	AL-SI

D	Embrayage / Clutch		
	Poids de l'embrayage assemblé / Weight of the clutch assembly	765 gr	minimum
	Dimensions de l'embrayage / Dimensions of the clutch	Selon dessin technique n°26 / according to technical drawing no. 26	
	Poids de l'embrayage / Weight of the clutch	350 gr	±15 gr
	Diamètre interne de la cloche d'embrayage / Internal diameter of clutch bell	85.00 mm	maximum

Dessin de l'embrayage assemblé / Drawing of the clutch assembly

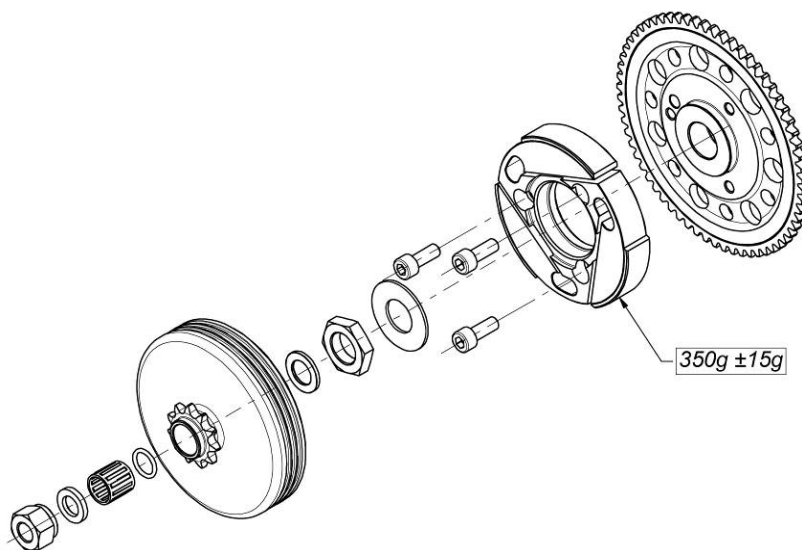

E

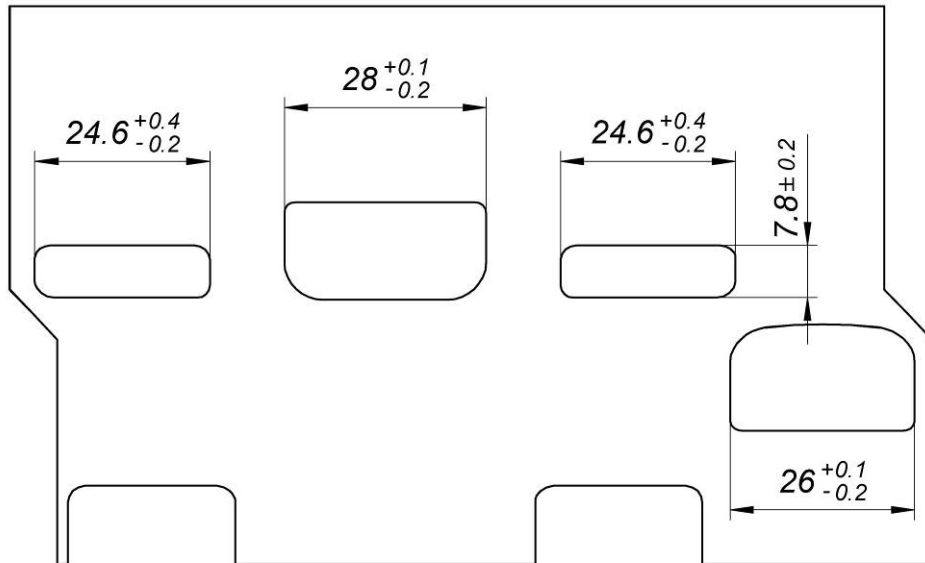
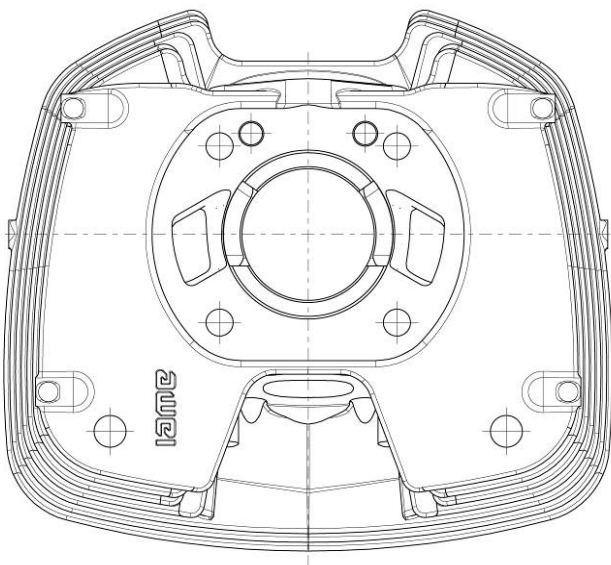
Photos, dessins et graphiques / *Photos, drawings and graphs*1. Cylindre / *Cylinder*Dessin du développement du cylindre (avec dimensions) /
Drawing of the cylinder development (with dimensions)Dessin du pied du cylindre /
*Drawing of the cylinder base*Photo du pied du cylindre / *Photo of the cylinder base*

Vue en coupe verticale du cylindre complet
(avec distance minimale de la surface d'appui du carburateur par rapport à l'axe du cylindre) /
Vertical cross section view of the complete cylinder
(with minimum distance of the carburettor support surface to cylinder axis)

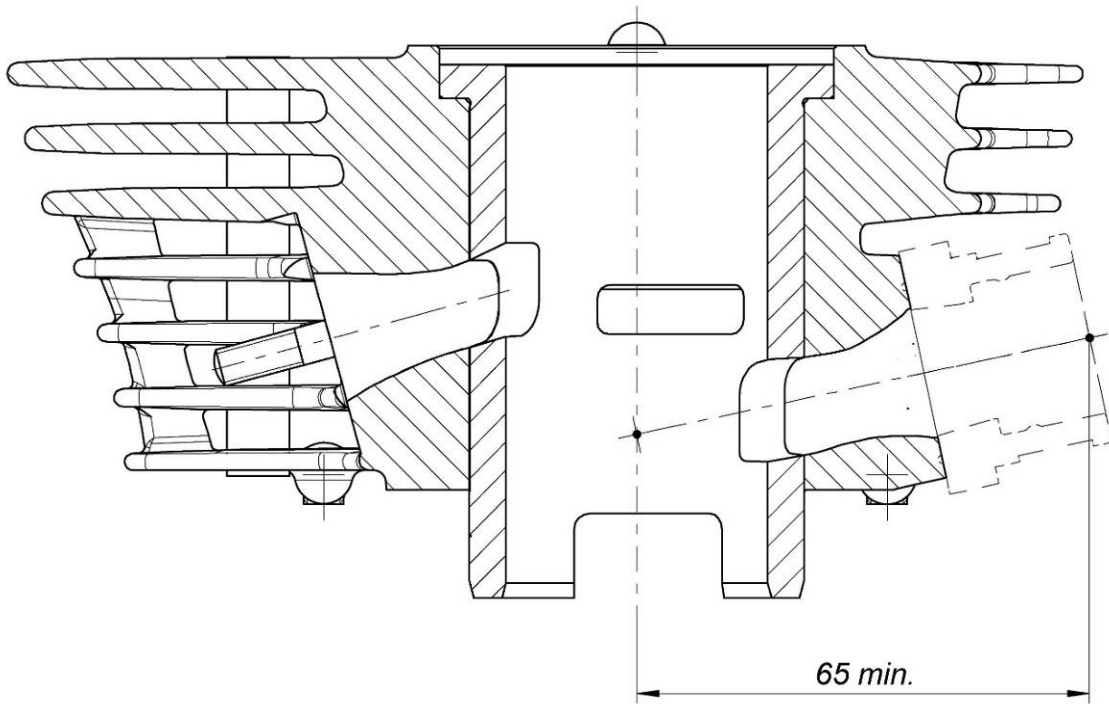

Dessin du collecteur d'échappement (dimensions principales avec tolérances) /
Drawing of exhaust manifold (main dimensions with tolerances)

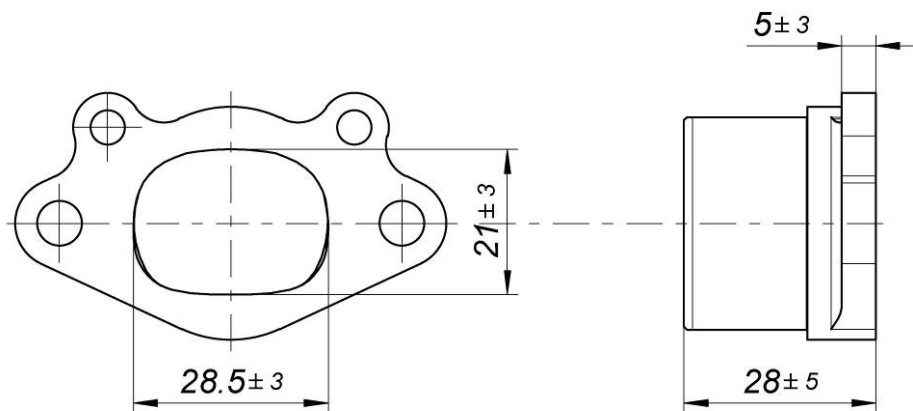

**Dessin de la culasse et de la chambre de combustion (sans dimensions) /
Drawing of the cylinder head and the combustion chamber (without dimensions)**

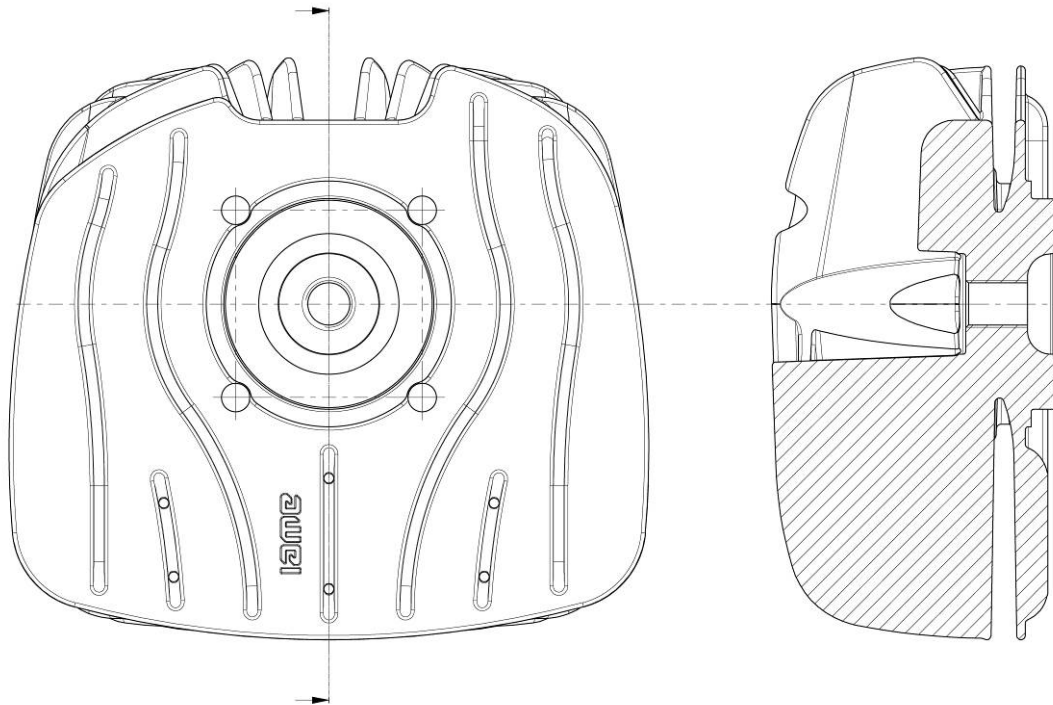
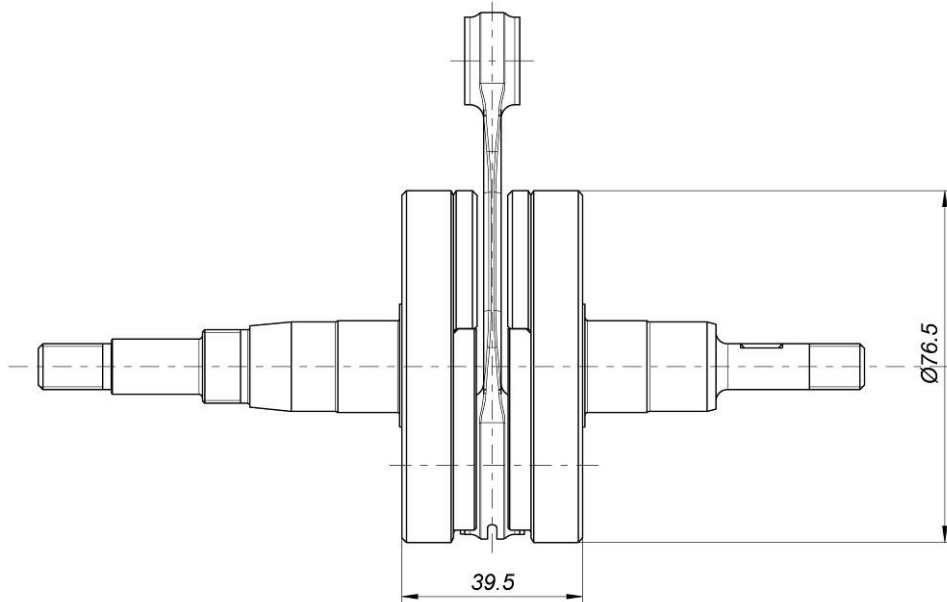

**Photo de la culasse et de la chambre de combustion /
Photo of the cylinder head and the combustion chamber**



**2. Vilebrequin, bielle, piston et carter /
Crankshaft, conrod, piston and crankcase**

**Dessin du vilebrequin complet (dimensions sans tolérances) /
Drawing of the complete crankshaft (dimensions without tolerances)**



**Photos de demi-vilebrequins (une avec contreponds en plastique, une sans) /
Photos of crankshaft halves (one with plastic counterweight, one without)**



**Photo du vilebrequin et de la bielle /
Photo of the crankshaft and conrod**



Photo de la bielle droite / Photo of the conrod right



Photo de la bielle gauche / Photo of the conrod left



**Dessin du piston (dimensions principales sans tolérances et gabarit) /
Drawing of the piston (main dimensions without tolerances and template)**

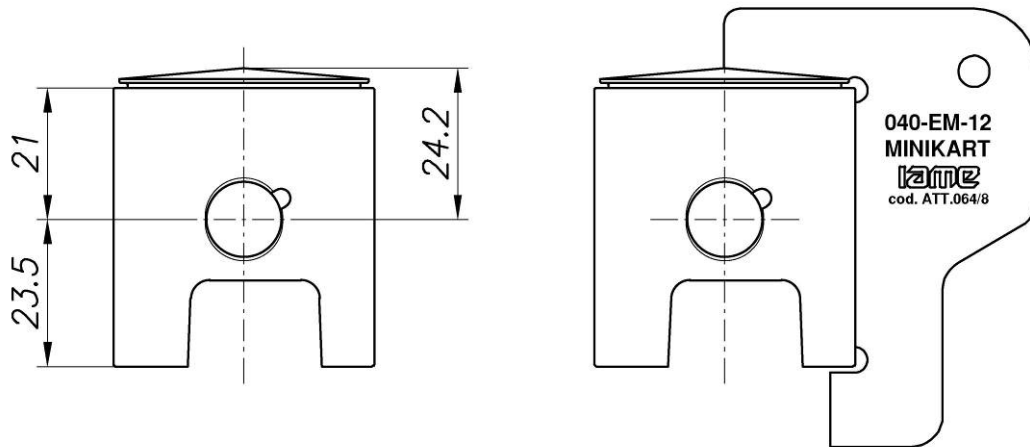
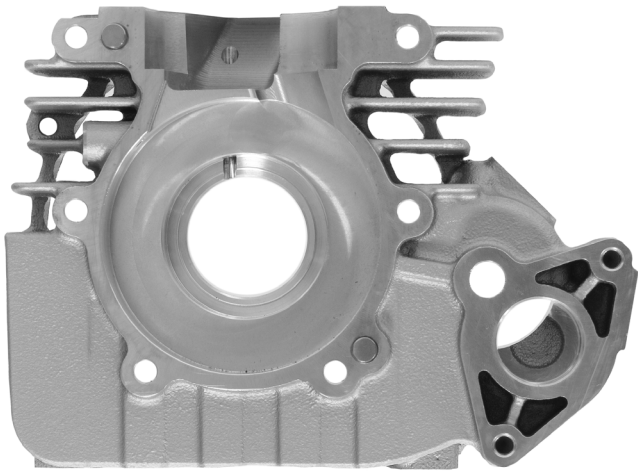

Photo du piston (de l'avant, de côté et d'en haut) / Photo of the piston (front, side and top)



**Photo de l'intérieur du carter droit /
Photo of the inside of the right crankcase**



**Photo de l'intérieur du carter gauche /
Photo of the inside of the left crankcase**

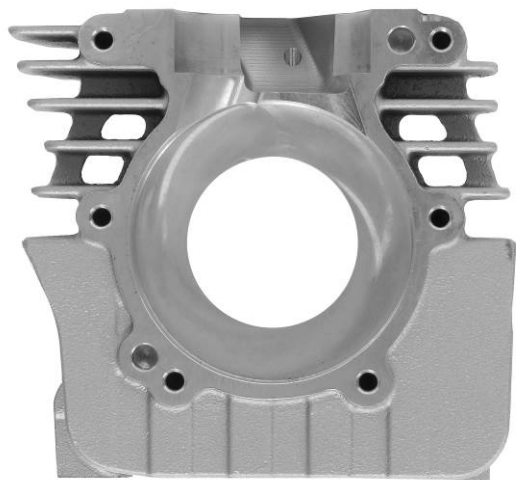

**Photo de l'extérieur du carter droit /
Photo of the outside of the right crankcase**

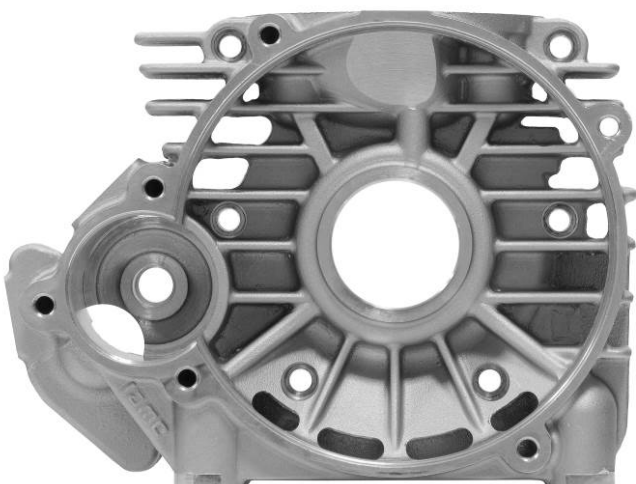

**Photo de l'extérieur du carter gauche /
Photo of the outside of the left crankcase**



**Photo du moteur côté pignon /
Photo of the engine drive side**



**Photo du moteur côté opposé /
Photo of the engine opposite side**



**Photo du moteur complet vu de l'avant /
Photo of the complete engine front side**

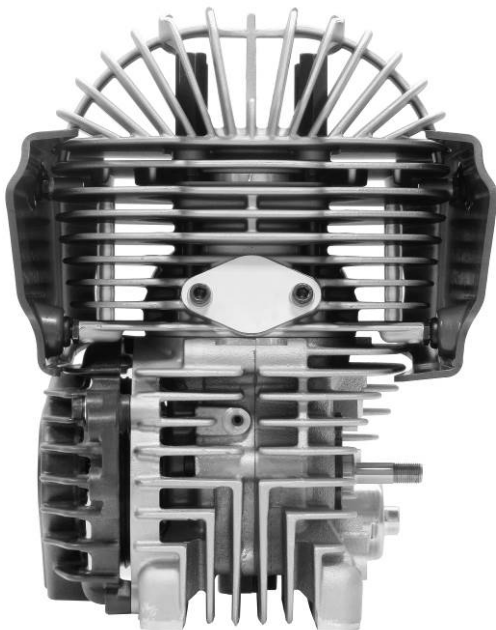

**Photo du moteur complet vu de l'arrière /
Photo of the complete engine rear side**



**Photo du moteur complet vu du haut /
Photo of the complete engine taken from above**

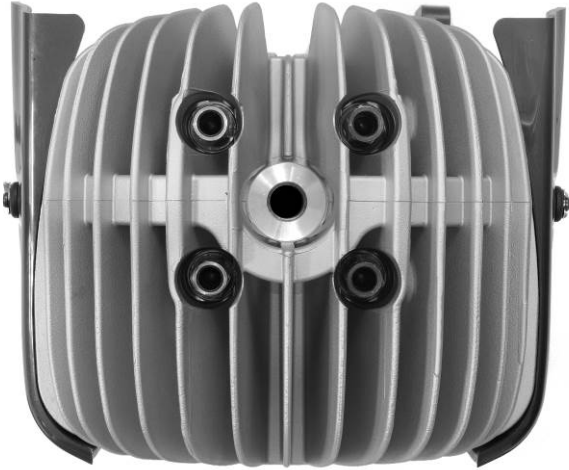

**Photo du moteur complet vu du dessous /
Photo of the complete engine taken from below**



**Photo des pièces plastiques du cylindre /
Photo of the cylinder plastic parts**



**Photo du protège-chaîne et du couvercle d'allumage /
Photo of the chain guard and ignition cover**







F





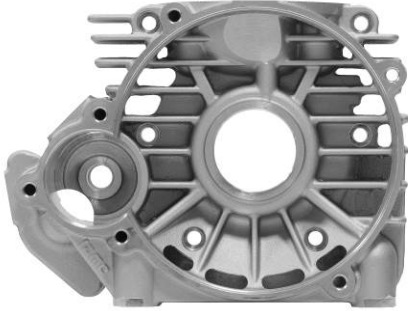

Marquage des pièces principales / Main parts marking

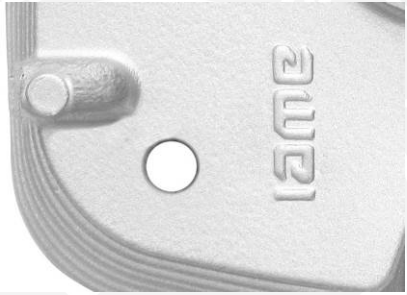
**Pour chaque pièce, photo d'ensemble avec le marquage et photo avec zoom sur le marquage /
For each part, overall photo with marking and zoomed photo of marking**

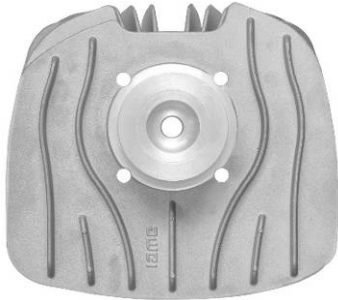
1. Fonderies des carters droit et gauche
2. Cylindre
3. Culasse
4. Chemise en fonte
5. Demi-vilebrequins
6. Bielle
7. Piston

1. Castings of LH & RH crankcases
2. Cylinder
3. Cylinder head
4. Cast iron liner
5. Half-crankshafts
6. Conrod
7. Piston

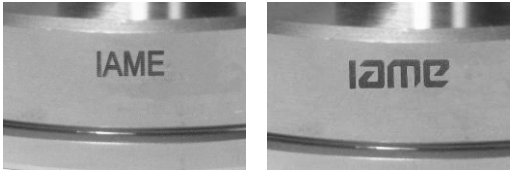
Pièces N° / Parts no.	Photo d'ensemble / Overall picture	Zoom
1		
1		
2		

3		
4		
5		
6		
7	